



PLX-Pure Lead High Rate PLX12-330 (12V330W)



Specifications

Rated Voltage	12V	
Nominal Rate ($W_{15}, 1.67V/cell$)	330W	
Nominal Capacity($C_{20}, 1.80V/cell$)	80Ah	
Dimension	Length	260±2mm (10.24 inches)
	Width	168±2mm (6.61 inches)
	Container Height	208±2mm (8.19 inches)
	Total Height	211±2mm (8.31 inches)
Approx. Weight	25.0 Kg (55.1 lbs)	
Terminal	M6	
Container Material	PC-ABS flame retardant jar and cover to UL94 V-0	
Rated Capacity (25°C)	8.32 Ah	(20hr, 4.16A, 1.80V/cell)
	80.0 Ah	(10hr, 8.00A, 1.80V/cell)
	75.0 Ah	(5hr, 15.0A, 1.75V/cell)
	66.3 Ah	(3hr, 22.1A, 1.75V/cell)
	58.6 Ah	(1hr, 58.6A, 1.67V/cell)
Max. Discharge Current	960A	
Internal Resistance (25°C)	Approx. 3.80mΩ(Fully charged)	
Operating Temp. Range	Discharge	-40 ~ 65°C (-40 ~ 149°F)
	Charge	0 ~ 40°C (32 ~ 104°F)
	Storage	-20 ~ 40°C (-4 ~ 104°F)
Nominal Operating Temp. Range	25±3°C (77±5°F)	
Max. Charging Current(25°C)	24.0A	
Charge voltage(25°C)	Float	13.62V
	Temp. Coefficient	-3mV/cell/°C
	Equalization	14.1~14.4V
Effect of temp. to Capacity	40°C (104°F)	103%
	25°C (77°F)	100%
	0°C (32°F)	86%
Self Discharge	<p>PLX series batteries can be stored up to 24 months at 25°C(77°F), For higher temperatures the time interval will be shorter.</p> <p>Battery needs to be given a freshening charge when the OCV approach 2.10V/cell or when the maximum storage time is reached, whichever occurs first.</p>	



Layout

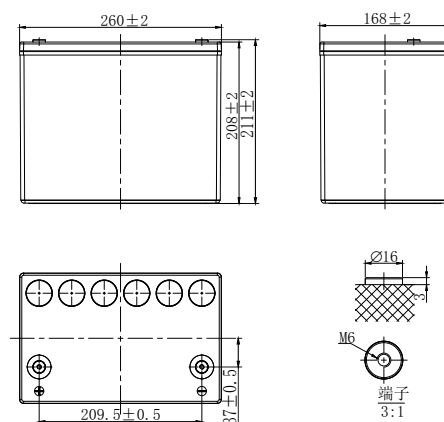

Constant Current Discharge (Amperes) at 25 °C (77° F)

F.V/Time	5min	10min	15min	20min	30min	45min	1h	2h	3h	4h	5h	8h	10h	20h
1.85V/cell	195.8	157.9	133.2	116.6	86.7	64.3	51.6	28.8	20.6	16.6	14.1	9.54	7.84	4.08
1.80V/cell	225.5	182.1	148.4	127.4	92.6	67.6	53.7	30.2	21.5	17.2	14.7	9.86	8.00	4.16
1.75V/cell	246.5	199.3	160.8	136.0	98.6	69.5	55.2	31.0	22.1	17.7	15.0	10.0	8.11	4.21
1.70V/cell	265.5	215.5	171.1	143.0	102.4	72.0	57.4	31.5	22.5	18.0	15.3	10.1	8.21	4.25
1.67V/cell	296.4	227.0	180.4	148.5	106.5	74.8	58.6	32.0	22.8	18.2	15.4	10.2	8.27	4.28
1.60V/cell	320.4	230.9	186.5	152.7	108.6	76.0	59.6	32.5	23.1	18.4	15.6	10.3	8.32	4.31

Constant Power Discharge (Watts/cell) at 25 °C (77° F)

F.V/Time	5min	10min	15min	20min	30min	45min	1h	2h	3h	4h	5h	8h	10h	20h
1.85V/cell	375.9	308.9	262.0	230.5	172.3	128.4	103.3	58.0	41.7	33.6	28.7	19.5	16.1	8.44
1.80V/cell	426.9	352.6	289.1	249.5	182.6	133.9	106.8	60.2	43.2	34.7	29.8	20.1	16.4	8.56
1.75V/cell	461.1	382.3	310.5	263.8	192.5	136.5	109.0	61.5	44.1	35.5	30.3	20.3	16.5	8.62
1.70V/cell	488.8	408.8	326.4	274.6	197.8	140.0	112.3	62.0	44.6	35.8	30.5	20.4	16.6	8.66
1.67V/cell	538.1	427.4	330.0	283.5	204.8	144.6	114.2	62.8	44.9	36.1	30.7	20.5	16.7	8.68
1.60V/cell	600.0	430.5	350.1	288.6	206.6	145.6	115.0	63.2	45.0	36.2	30.7	20.5	16.7	8.71



PLX-Pure Lead High Rate PLX12-330 (12V330W)

Applications

- UPS
- Emergency lighting
- Emergency power supply
- Electrical starting
- Power tools

General Features

- 15 years design life(25°C)
- Premium ABS+PC jar & covers, Flame Retardant to UL94 V-0
- High-rate performance, high energy density
- High quality AGM separators minimize electrical resistance to allow high current discharging properties

Standards

- Classified as "Very Long Life" according to Eurobat
- CE Certified
- Manufactured in Leoch@IATF16949, OHSAS 18001, ISO 9001 and ISO 14001 certified production facilities

Discharge Characteristics

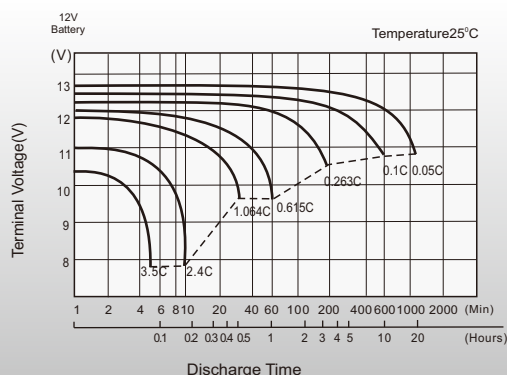

Float Charging Characteristics

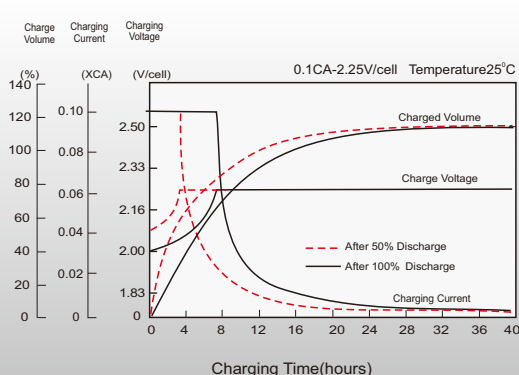

Effects of Temperature on Discharging Time

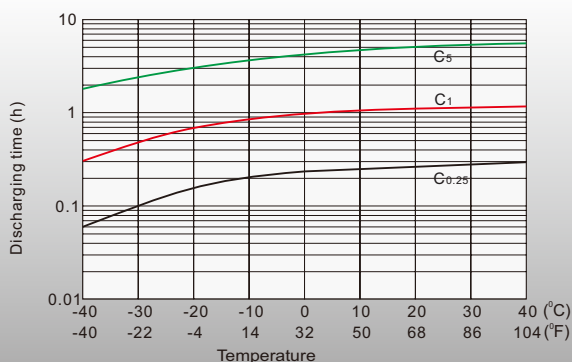

Self-discharge Characteristics

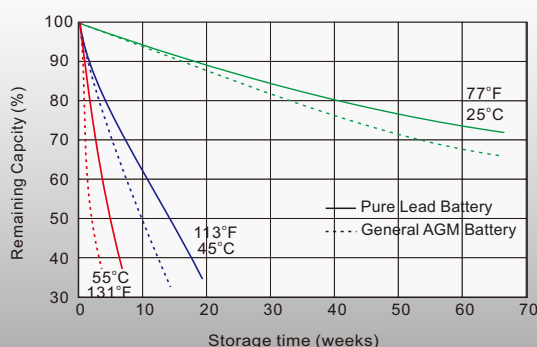

Sales Offices Worldwide

China Sales Office

5th Floor, Xinbaohui Bldg., Nanhai Blvd.,
Nanshan, Shenzhen, China. 518052
Tel: +86-755-86036060 (100 lines)
Fax: +86-755-26067269
E-mail: export@leoch.com

HongKong Sales Office

Workshop C, 33/F, TML Tower, No. 3 Hoi Shing Road,
Tsuen Wan, New Territories, Hong Kong
Tel: +852 35786666
Fax: +44 1452 690125
E-mail: sales.hk@leoch.com

Singapore Sales Office

No. 1 Tech Park Crescent,
Singapore 638131
Tel: +65 68636078
Fax: +65 6863 6079
Email: sales.sg@Leoch.com

Australia Sales Office

2 /29 Tarlington Place, Smithfield. NSW 2164
Australia
Tel: 02 9756 0950
E-mail: sales.au@leoch.com

North America Sales Office

19751 Descartes
Foothill Ranch, CA 92610, USA
Tel: 949-588-5853
Fax: 949-588-5966
E-mail: sales@leoch.us

UK Sales Office

9B Wheatstone Court, Waterwells, Business Park,
Gloucester, GL2-2AQ, UK United Kingdom
Tel: +44(0) 1452 729428 / 1452 729696
Fax: +44 1452 690125
E-mail: Sales.Europe@leoch.com

EMEA Sales Office

1 Deligiorgi St., 121 31 Athens,
Greece
Tel: +30 210 5760318 (2 lines)
E-mail: support_EMEA@leoch.com

India Sales Office

Shed no. A-53(b), 2nd Stage of Peenya Industrial Area,
Bangalore North Taluk, Bangalore-560058, India
Tel: +91-80-23440018/23440019
Fax: +91-80-23440017
E-mail: indiasales@leoch.com



[Http://www.leoch.com](http://www.leoch.com)
[Http://www.leoch.us](http://www.leoch.us)

© 2019 LEOCH. All rights reserved.

Trademarks and logos are the property of LEOCH and its affiliates unless otherwise noted.
Subject to revisions without prior notice.

Publication No.: LB-PLX12-330-PD-EN-V1.0-201906