



PLX-Pure Lead High Rate

PLX12-400FT(A) (12V405W)

Specifications

Rated Voltage	12V	
Nominal Rate (W_{15} , 1.67V/cell)	405W	
Nominal Capacity(C_{10} , 1.80V/cell)	100Ah	
Dimension	Length	405.4±2mm (15.96 inches)
	Width	108±2mm (4.25 inches)
	Container Height	287±2mm (11.30 inches)
	Total Height	287±2mm (11.30 inches)
Approx. Weight	31.5 Kg (69.4 lbs)	
Terminal	M6	
Container Material	PC-ABS flame retardant jar and cover to UL94 V-0	
Rated Capacity (25°C)	104.0 Ah	(20hr, 5.20A, 1.80V/cell)
	100.0 Ah	(10hr, 10.0A, 1.80V/cell)
	87.5 Ah	(5hr, 17.5A, 1.75V/cell)
	77.7 Ah	(3hr, 25.9A, 1.75V/cell)
	70.0 Ah	(1hr, 70.0A, 1.67V/cell)
Max. Discharge Current	1200A	
Internal Resistance (25°C)	Approx. 4.4mΩ(Fully charged)	
Operating Temp. Range	Discharge	-40 ~ 65°C (-40 ~ 149°F)
	Charge	0 ~ 40°C (32 ~ 104°F)
	Storage	-20 ~ 40°C (-4 ~ 104°F)
Nominal Operating Temp. Range	25±3°C (77±5°F)	
Max. Charging Current(25°C)	30.0A	
Charge voltage(25°C)	Float	13.62V
	Temp. Coefficient	-3mV/cell/°C
	Equalization	14.1~14.4V
Effect of temp. to Capacity	40°C (104°F)	103%
	25°C (77°F)	100%
	0°C (32°F)	86%
Self Discharge	<p>PLX series batteries can be stored up to 24 months at 25°C(77°F), For higher temperatures the time interval will be shorter.</p> <p>Battery needs to be given a freshening charge when the OCV approach 2.10V/cell or when the maximum storage time is reached, whichever occurs first.</p>	



Layout

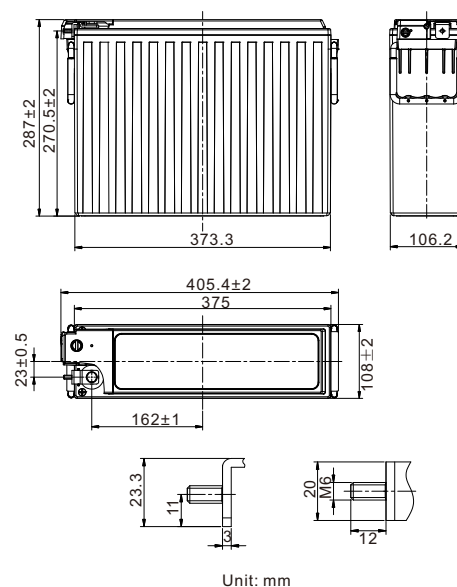

Constant Current Discharge (Amperes) at 25 °C (77° F)

F.V/Time	5min	10min	15min	20min	30min	45min	1h	2h	3h	4h	5h	8h	10h	20h
1.85V/cell	303.6	228.6	184.3	153.9	113.6	80.0	61.9	34.1	24.7	19.8	16.7	11.7	9.79	5.10
1.80V/cell	329.6	242.8	193.4	159.9	118.4	82.7	63.9	35.2	25.4	20.4	17.2	11.9	10.0	5.20
1.75V/cell	350.9	255.6	200.4	166.2	122.4	85.2	65.8	36.1	25.9	20.7	17.5	12.1	10.1	5.24
1.70V/cell	373.3	263.7	207.5	171.6	126.6	88.0	67.7	36.9	26.4	21.0	17.7	12.2	10.1	5.28
1.67V/cell	390.0	274.8	213.0	177.3	132.0	91.3	70.0	37.9	26.9	21.4	17.9	12.3	10.2	5.31
1.60V/cell	410.0	279.4	225.0	185.1	135.0	93.7	71.7	38.6	27.3	21.7	18.1	12.4	10.3	5.35

Constant Power Discharge (Watts/cell) at 25 °C (77° F)

F.V/Time	5min	10min	15min	20min	30min	45min	1h	2h	3h	4h	5h	8h	10h	20h
1.85V/cell	569.0	438.9	357.7	299.5	222.7	158.3	122.8	68.0	49.4	39.7	33.6	23.7	19.9	10.4
1.80V/cell	611.0	461.2	372.9	309.2	230.6	162.3	126.0	69.9	50.6	40.7	34.5	24.1	20.3	10.6
1.75V/cell	642.4	480.1	382.6	318.4	236.4	166.1	128.9	71.4	51.3	41.2	34.9	24.3	20.4	10.6
1.70V/cell	667.2	491.6	392.2	325.7	242.5	170.5	131.8	72.5	52.1	41.7	35.2	24.5	20.4	10.7
1.67V/cell	670.0	501.2	405.0	333.0	245.0	176.0	135.5	74.1	52.9	42.2	35.6	24.6	20.5	10.7
1.60V/cell	710.0	506.1	410.0	343.9	250.0	178.8	137.7	75.0	53.5	42.6	35.7	24.7	20.6	10.7



PLX-Pure Lead High Rate PLX12-400FT(A) (12V405W)



Applications

- UPS
- Emergency lighting
- Emergency power supply
- Electrical starting
- Power tools

General Features

- 15 years design life(25°C)
- Premium ABS+PC jar & covers, Flame Retardant to UL94 V-0
- High-rate performance, high energy density
- High quality AGM separators minimize electrical resistance to allow high current discharging properties

Standards

- Compliance with IEC 60896 standard
- Classified as "Very Long Life" according to Eurobat
- CE, UL Certified
- Manufactured in Leoch®IATF 16949, OHSAS 18001, ISO 9001 and ISO 14001 certified production facilities

Discharge Characteristics

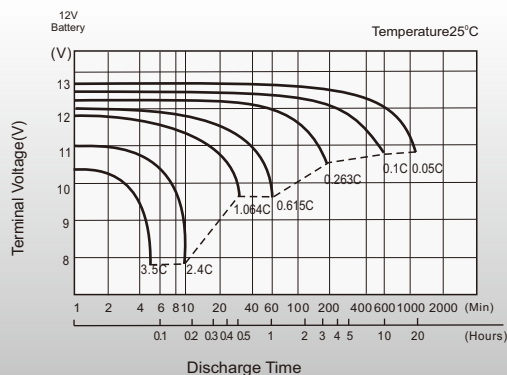

Float Charging Characteristics

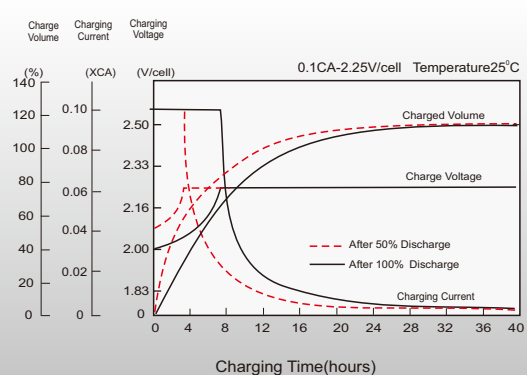

Effects of Temperature on Discharging Time

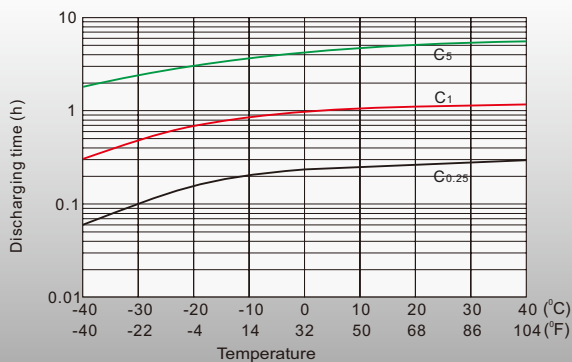

Self-discharge Characteristics

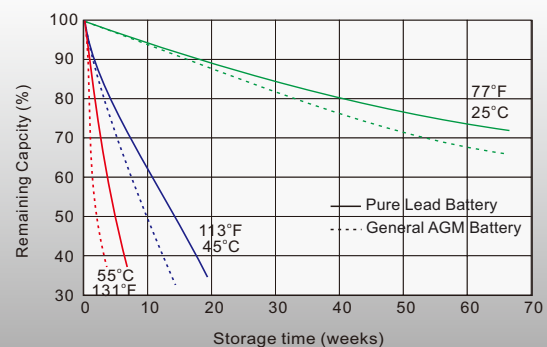

Sales Offices Worldwide

China Sales Office

5th Floor, Xinbaohui Bldg., Nanhai Blvd.,
Nanshan, Shenzhen, China. 518052
Tel: +86-755-86036060 (100 lines)
Fax: +86-755-26067269
E-mail: export@leoch.com

HongKong Sales Office

Workshop C, 33/F, TML Tower, No. 3 Hoi Shing Road,
Tsuen Wan, New Territories, Hong Kong
Tel: +852 35786666
Fax: +44 1452 690125
E-mail: sales.hk@leoch.com

Singapore Sales Office

No. 1 Tech Park Crescent,
Singapore 638131
Tel: +65 68636078
Fax: +65 6863 6079
Email: sales.sg@Leoch.com

Australia Sales Office

2 /29 Tarlington Place, Smithfield. NSW 2164
Australia
Tel: 02 9756 0950
E-mail: sales.au@leoch.com

North America Sales Office

19751 Descartes
Foothill Ranch, CA 92610, USA
Tel: 949-588-5853
Fax: 949-588-5966
E-mail: sales@leoch.us

UK Sales Office

9B Wheatstone Court, Waterwells, Business Park,
Gloucester, GL2-2AQ, UK United Kingdom
Tel: +44(0) 1452 729428 / 1452 729696
Fax: +44 1452 690125
E-mail: Sales.Europe@leoch.com

EMEA Sales Office

1 Deligiorgi St., 121 31 Athens,
Greece
Tel: +30 210 5760318 (2 lines)
E-mail: support_EMEA@leoch.com

India Sales Office

Shed no. A-53(b), 2nd Stage of Peenya Industrial Area,
Bangalore North Taluk, Bangalore-560058, India
Tel: +91-80-23440018/23440019
Fax: +91-80-23440017
E-mail: indiasales@leoch.com



[Http://www.leoch.com](http://www.leoch.com)
[Http://www.leoch.us](http://www.leoch.us)

© 2019 LEOCH. All rights reserved.
Trademarks and logos are the property of LEOCH and its affiliates unless otherwise noted.
Subject to revisions without prior notice.

Publication No.: LB-PLX12-400FT(A)-PD-EN-V3.1-201904