



PLX-Pure Lead High Rate PLX12-730FT (12V730W)



Specifications

Rated Voltage	12V	
Nominal Rate ($W_{15}, 1.67V/cell$)	730W	
Nominal Capacity($C_{10}, 1.80V/cell$)	200Ah	
Dimension	Length	571±2mm (22.48 inches)
	Width	125±2mm (4.92 inches)
	Container Height	320±2mm (12.60 inches)
	Total Height	320±2mm (12.60 inches)
Approx. Weight	61.0 Kg (134.2 lbs)	
Terminal	M6	
Container Material	PC-ABS flame retardant jar and cover to UL94 V-0	
Rated Capacity (25°C)	208.0 Ah	(20hr, 10.4A, 1.80V/cell)
	200.0 Ah	(10hr, 20.0A, 1.80V/cell)
	171.0 Ah	(5hr, 34.2A, 1.75V/cell)
	156.6 Ah	(3hr, 52.2A, 1.75V/cell)
	137.0 Ah	(1hr, 137.0A, 1.67V/cell)
Max. Discharge Current	1500A	
Internal Resistance (25°C)	Approx. 3.0mΩ(Fully charged)	
Operating Temp.Range	Discharge	-40 ~ 65°C (-40 ~ 149°F)
	Charge	0 ~ 40°C (32 ~ 104°F)
	Storage	-20 ~ 40°C (-4 ~ 104°F)
Nominal Operating Temp. Range	25±3°C (77±5°F)	
Max.Charging Current(25°C)	60.0A	
Charge voltage(25°C)	Float	13.62V
	Temp. Coefficient	-3mV/cell/°C
	Equalization	14.1~14.4V
Effect of temp. to Capacity	40°C (104°F)	103%
	25°C (77°F)	100%
	0°C (32°F)	86%
Self Discharge	<p>PLX series batteries can be stored up to 24 months at 25°C(77°F), For higher temperatures the time interval will be shorter.</p> <p>Battery needs to be given a freshening charge when the OCV approach 2.10V/cell or when the maximum storage time is reached, whichever occurs first.</p>	

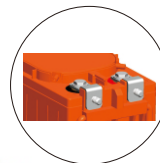

Layout

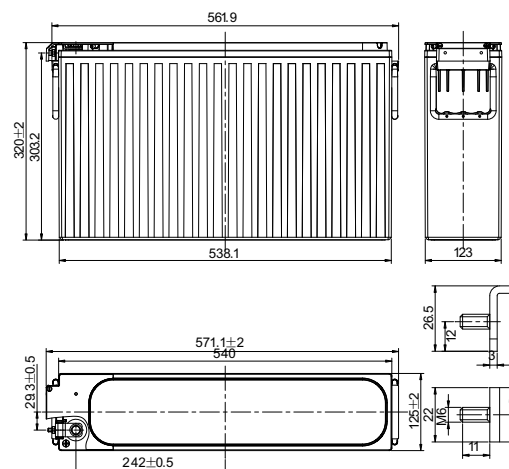

Constant Current Discharge (Amperes) at 25 °C (77° F)

F.V/Time	5min	10min	15min	20min	30min	45min	1h	2h	3h	4h	5h	8h	10h	20h
1.85V/cell	420.0	356.4	312.0	268.2	202.8	149.6	118.4	68.3	49.3	38.7	32.3	22.5	19.4	10.1
1.80V/cell	482.4	398.4	348.0	296.4	218.8	159.2	125.1	70.7	51.2	40.0	33.4	23.3	20.0	10.4
1.75V/cell	525.6	429.6	370.4	316.2	232.4	167.2	131.1	72.3	52.2	41.1	34.2	23.7	20.3	10.6
1.70V/cell	576.0	460.2	389.6	330.0	243.6	174.4	135.4	74.2	53.4	41.9	34.8	24.1	20.5	10.7
1.67V/cell	689.5	487.2	402.2	343.2	252.2	180.0	137.0	75.6	54.0	42.2	35.3	24.5	20.6	10.8
1.60V/cell	705.4	513.6	419.5	352.2	259.8	185.1	140.2	76.8	54.3	42.6	35.6	24.6	20.8	10.9

Constant Power Discharge (Watts/cell) at 25 °C (77° F)

F.V/Time	5min	10min	15min	20min	30min	45min	1h	2h	3h	4h	5h	8h	10h	20h
1.85V/cell	782.0	679.3	602.4	522.0	397.5	295.9	234.9	136.4	98.6	77.8	65.1	45.8	39.4	20.5
1.80V/cell	890.5	750.9	668.5	573.2	426.1	312.6	246.4	140.4	101.9	80.0	66.9	46.8	40.5	21.2
1.75V/cell	961.6	804.2	707.1	605.8	448.7	326.0	256.5	142.9	103.6	81.6	68.2	47.7	41.1	21.5
1.70V/cell	1026.4	848.2	724.8	626.3	466.6	337.9	263.7	146.1	105.5	83.1	69.3	48.5	41.4	21.7
1.67V/cell	1052.6	868.6	730.0	644.6	484.2	346.8	265.2	148.1	106.3	83.5	70.0	49.1	41.5	21.8
1.60V/cell	1115.8	886.9	736.5	654.3	500.0	353.1	269.4	149.5	106.8	83.9	70.3	49.2	41.8	21.9



PLX-Pure Lead High Rate PLX12-730FT (12V730W)



Applications

- UPS
- Emergency lighting
- Emergency power supply
- Electrical starting
- Power tools

General Features

- 15 years design life(25°C)
- Premium ABS+PC jar & covers, Flame Retardant to UL94 V-0
- High-rate performance, high energy density
- High quality AGM separators minimize electrical resistance to allow high current discharging properties

Standards

- Compliance with IEC 60896 standard
- Classified as "Very Long Life" according to Eurobat
- CE, UL Certified
- Manufactured in Leoch@IATF 16949, OHSAS 18001, ISO 9001 and ISO 14001 certified production facilities

Discharge Characteristics

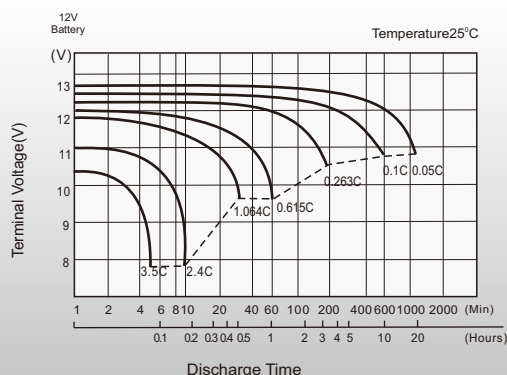

Float Charging Characteristics

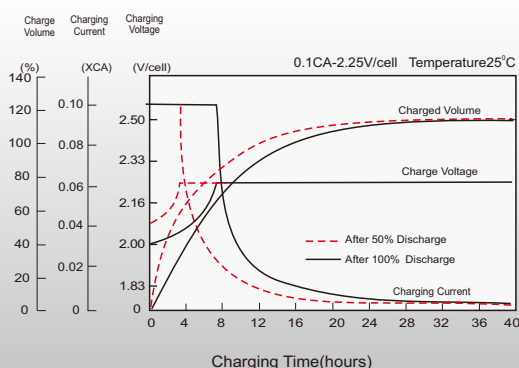

Effects of Temperature on Discharging Time

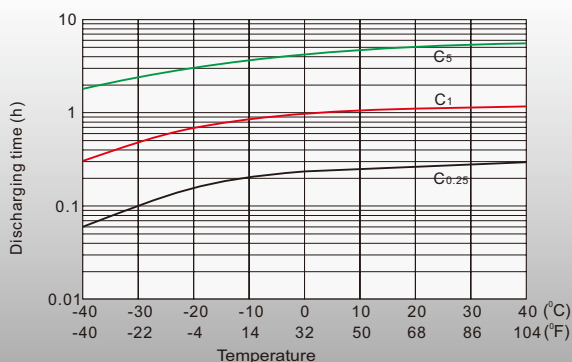

Self-discharge Characteristics

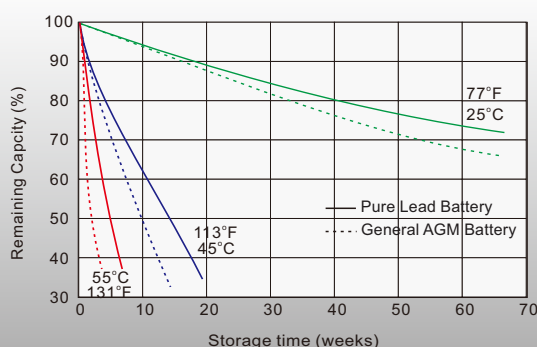

Sales Offices Worldwide

China Sales Office

5th Floor, Xinbaohui Bldg., Nanhai Blvd.,
Nanshan, Shenzhen, China. 518052
Tel: +86-755-86036060 (100 lines)
Fax: +86-755-26067269
E-mail: export@leoch.com

HongKong Sales Office

Workshop C, 33/F, TML Tower, No. 3 Hoi Shing Road,
Tsuen Wan, New Territories, Hong Kong
Tel: +852 35786666
Fax: +44 1452 690125
E-mail: sales.hk@leoch.com

Singapore Sales Office

No. 1 Tech Park Crescent,
Singapore 638131
Tel: +65 68636078
Fax: +65 6863 6079
Email: sales.sg@Leoch.com

Australia Sales Office

2 /29 Tarlington Place, Smithfield. NSW 2164
Australia
Tel: 02 9756 0950
E-mail: sales.au@leoch.com

North America Sales Office

19751 Descartes
Foothill Ranch, CA 92610, USA
Tel: 949-588-5853
Fax: 949-588-5966
E-mail: sales@leoch.us

UK Sales Office

9B Wheatstone Court, Waterwells, Business Park,
Gloucester, GL2-2AQ, UK United Kingdom
Tel: +44(0) 1452 729428 / 1452 729696
Fax: +44 1452 690125
E-mail: Sales.Europe@leoch.com

EMEA Sales Office

1 Deligiorgi St., 121 31 Athens,
Greece
Tel: +30 210 5760318 (2 lines)
E-mail: support_EMEA@leoch.com

India Sales Office

Shed no. A-53(b), 2nd Stage of Peenya Industrial Area,
Bangalore North Taluk, Bangalore-560058, India
Tel: +91-80-23440018/23440019
Fax: +91-80-23440017
E-mail: indiasales@leoch.com



[Http://www.leoch.com](http://www.leoch.com)
[Http://www.leoch.us](http://www.leoch.us)

© 2019 LEOCH. All rights reserved.

Trademarks and logos are the property of LEOCH and its affiliates unless otherwise noted.
Subject to revisions without prior notice.

Publication No.: LB-PLX12-730FT-PD-EN-V3.2-201906