



XP Series-Ultra High Rate

XP12-350(12V350W)



Specifications

Rated Voltage	12V	
Nominal Rate ($W_{15}, 1.67V/cell$)	370.3W/cell	
Nominal Capacity($C_{20}, 1.80V/cell$)	95Ah	
Dimension	Length	305±2mm (12.0 inches)
	Width	168±2mm (6.61 inches)
	Container Height	207±2mm (8.15 inches)
	Total Height	210±2mm (8.27 inches)
Approx. Weight	28.2 Kg (62.2 lbs)	
Terminal	M6	
Container Material	ABS	
Rated Capacity (25°C)	95.0 Ah	(20hr, 4.75A, 1.80V/cell)
	90.7 Ah	(10hr, 9.07A, 1.80V/cell)
	83.5 Ah	(5hr, 16.7A, 1.75V/cell)
	77.1 Ah	(3hr, 25.7A, 1.75V/cell)
	65.3 Ah	(1hr, 65.3A, 1.67V/cell)
Max. Discharge Current	1425A	
Internal Resistance (25°C)	Approx. 4.0mΩ	
Operating Temp. Range	Discharge	-15 ~ 50°C (5 ~ 122°F)
	Charge	0 ~ 40°C (32 ~ 104°F)
	Storage	-15 ~ 40°C (5 ~ 104°F)
Nominal Operating Temp. Range	25±3°C (77±5°F)	
Max. Charging Current(25°C)	28.5A	
Charge voltage(25°C)	Float	13.5V
	Temp. Coefficient	-3mV/cell/°C
	Equalization	14.1~14.4V
Effect of temp. to Capacity	40°C (104°F)	103%
	25°C (77°F)	100%
	0°C (32°F)	86%
Self Discharge	≤3%/month @ 25°C	



Layout

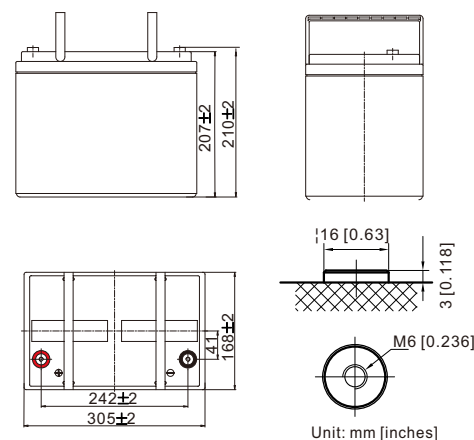

Constant Current Discharge (Amperes) at 25 °C (77°F)

F.V/Time	5min	10min	15min	20min	30min	45min	1h	2h	3h	4h	5h	6h	8h	10h	20h
1.85V/cell	209.8	171.1	145.5	123.1	95.0	69.9	56.5	33.7	24.4	19.1	15.8	13.6	10.7	8.84	4.63
1.80V/cell	234.8	190.7	158.5	133.1	100.7	73.4	59.2	35.0	25.1	19.8	16.3	14.0	10.9	9.07	4.75
1.75V/cell	262.2	209.2	171.4	142.2	105.8	76.7	61.6	35.8	25.7	20.1	16.7	14.3	11.2	9.25	4.86
1.70V/cell	290.7	226.9	182.4	151.3	111.2	80.1	63.5	36.6	26.2	20.6	17.1	14.6	11.4	9.43	4.94
1.67V/cell	321.5	242.8	195.3	159.6	116.5	82.8	65.3	37.3	26.7	21.0	17.3	14.9	11.6	9.59	5.03
1.60V/cell	348.8	258.8	205.6	166.7	120.4	85.8	67.5	38.3	27.2	21.4	17.7	15.2	11.9	9.76	5.16

Constant Power Discharge (Watts/cell) at 25 °C (77°F)

F.V/Time	5min	10min	15min	20min	30min	45min	1h	2h	3h	4h	5h	6h	8h	10h	20h
1.85V/cell	408.1	334.7	286.3	243.4	188.8	139.6	113.2	67.8	49.2	38.8	32.2	27.7	21.8	18.2	9.58
1.80V/cell	452.1	369.2	308.6	260.6	198.3	145.4	117.7	69.9	50.4	39.8	33.1	28.3	22.3	18.6	9.76
1.75V/cell	499.6	401.3	330.8	276.0	206.7	150.7	121.6	71.1	51.3	40.3	33.5	28.9	22.7	18.8	9.93
1.70V/cell	547.6	430.4	348.0	290.7	214.9	155.8	124.3	72.1	52.0	41.1	34.1	29.2	23.0	19.1	10.0
1.67V/cell	600.7	457.2	370.3	304.6	223.9	160.4	127.2	73.1	52.7	41.6	34.4	29.6	23.3	19.3	10.2
1.60V/cell	644.5	482.0	385.7	315.2	229.1	164.4	130.2	74.5	53.2	42.0	34.9	29.9	23.6	19.4	10.3



XP Series-Ultra High Rate

XP12-350(12V350W)



Applications

- UPS
- Hospitals & Testing Laboratories
- Emergency Power Supply
- Electric starting
- Telecommunications
- Data Centers

General Features

- Special designed grids for optimized high power density
- Oversized partition intercell welds, providing low resistance connections & minimal power loss
- Advanced lead tin calcium alloy, reduces grid corrosion & promotes long battery life
- Performance excels at high rates of discharge & recharge
- High integrity post seal for long life

Standards

- Compliance with IEC 60896 standards
- Classified as "Very Long Life" according to Eurobat
- CE, UL Certified
- Manufactured in Leoch®TS16949, OHSAS 18001, ISO 9001 and ISO 14001 certified production facilities

Discharge Characteristics

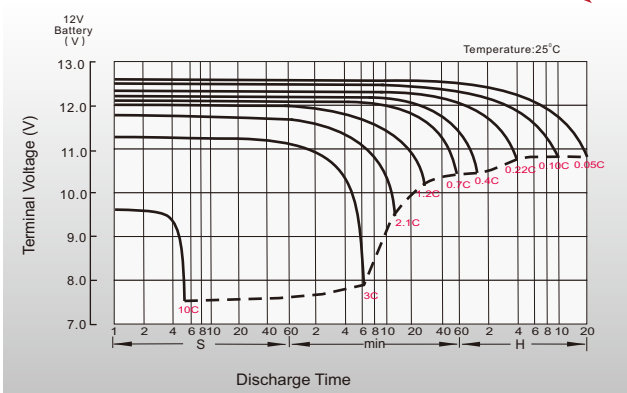

Float Charging Characteristics

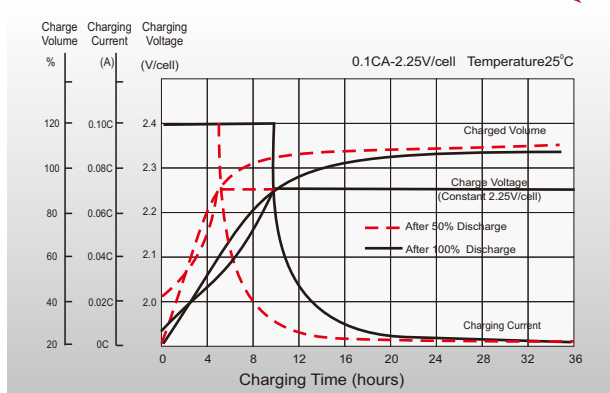

Temperature Effects in Relation to Battery Capacity

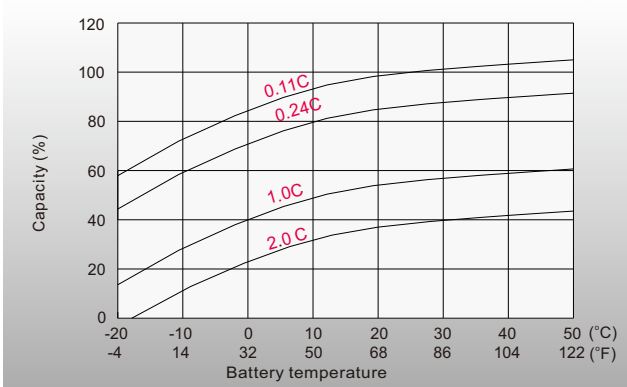

Temperature Effects on Long Term Float Life

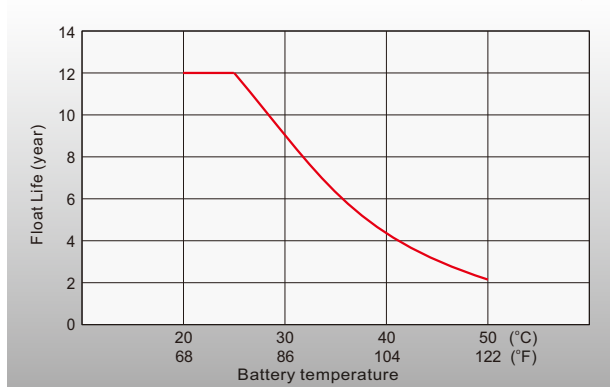

Sales Offices Worldwide

China Sales Office

5th Floor, Xinhaohui Bldg., Nanhai Blvd.,
Nanshan, Shenzhen, China. 518052
Tel: +86-755-86036060 (100 lines)
Fax: +86-755-26067269
E-mail: export@leoch.com

HongKong Sales Office

Workshop C, 33/F, TML Tower, No. 3 Hoi Shing Road,
Tsuen Wan, New Territories, Hong Kong
Tel: +852 35786666
Fax: +44 1452 690125
E-mail: sales.hk@leoch.com

Singapore Sales Office

No. 1 Tech Park Crescent,
Singapore 638131
Tel: +65 68636078
Fax: +65 6863 6079
Email: sales.sg@Leoch.com

Australia Sales Office

2 /29 Tarlington Place, Smithfield. NSW 2164
Australia
Tel: 02 9756 0950
E-mail: sales.au@leoch.com

North America Sales Office

19751 Descartes
Foothill Ranch, CA 92610, USA
Tel: 949-588-5853
Fax: 949-588-5966
E-mail: sales@leoch.us

UK Sales Office

9B Wheatstone Court, Waterwells, Business Park,
Gloucester, GL2-2AQ, UK United Kingdom
Tel: +44(0) 1452 729428 / 1452 729696
Fax: +44 1452 690125
E-mail: Sales.Europe@leoch.com

EMEA Sales Office

1 Deligiorgi St., 121 31 Athens,
Greece
Tel: +30 210 5760318 (2 lines)
E-mail: support_EMEA@leoch.com

India Sales Office

Shed no. A-53(b), 2nd Stage of Peenya Industrial Area,
Bangalore North Taluk, Bangalore-560058, India
Tel: +91-80-23440018/23440019
Fax: +91-80-23440017
E-mail: indiasales@leoch.com



<http://www.leoch.com>
<http://www.leoch.us>

© 2018 LEOCH. All rights reserved.

Trademarks and logos are the property of LEOCH and its affiliates unless otherwise noted.
Subject to revisions without prior notice.

Publication No.: LB-XP12-350-PD-EN-V2.0-201811